



Peak Emission Wavelength: 275nm

The DUVZ2753KBL9 B2 emitter is a specifically designed for applications requiring high radiant power output and accuracy in a TO-5 package with a special UV glass lens for optimum life time and device performance. Custom package solutions and sorting are available.

FEATURES

- > TO-5 Metal Can Package
- > High Reliability
- > Narrow Viewing Angle

APPLICATIONS

- > UV Curing / Light Therapy / Drug Discovery
- > Air and Water Disinfection
- > DNA / Protein Analysis

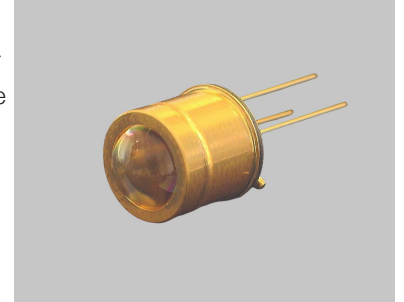

Absolute Maximum Ratings (Ta=25°C)



ITEMS	SYMBOL	RATINGS	UNIT
Forward Current	IF	30	mA
Operating Temperature	Topr	0 ~ +60	°C
Storage Temperature	Tstg	-40 ~ +100	°C
Junction Temperature	Tj	85	°C
Soldering Temperature*1	Tsol	300	°C

*1: Within 5 seconds.

Electrical & Optical Characteristics (Ta = 25°C)

ITEMS	SYMBOL	CONDITIONS	MIN.	TYP	MAX.	UNIT
Forward Voltage	VF	IF=20mA	--	5.2	--	V
Peak Wavelength	λ_p	IF=20mA	--	275	--	nm
Power Output	PO	IF=20mA	--	2.2	--	mW
Spectral Line Half Width	$\Delta\lambda$	IF=20mA	--	10	--	nm
View Angle	θ	IF=20mA	--	9.8	--	deg



Package Dimensions

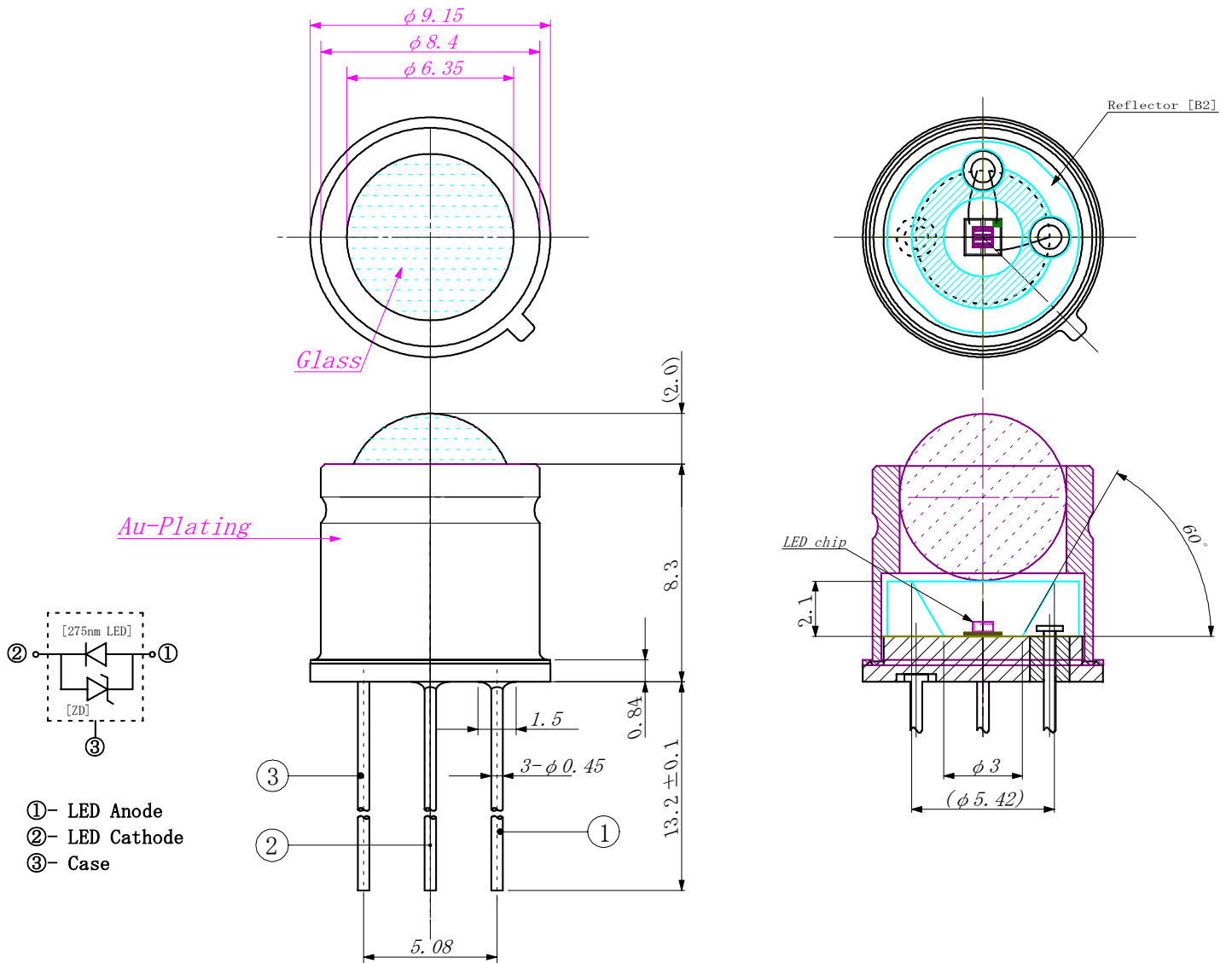



Spectral Response

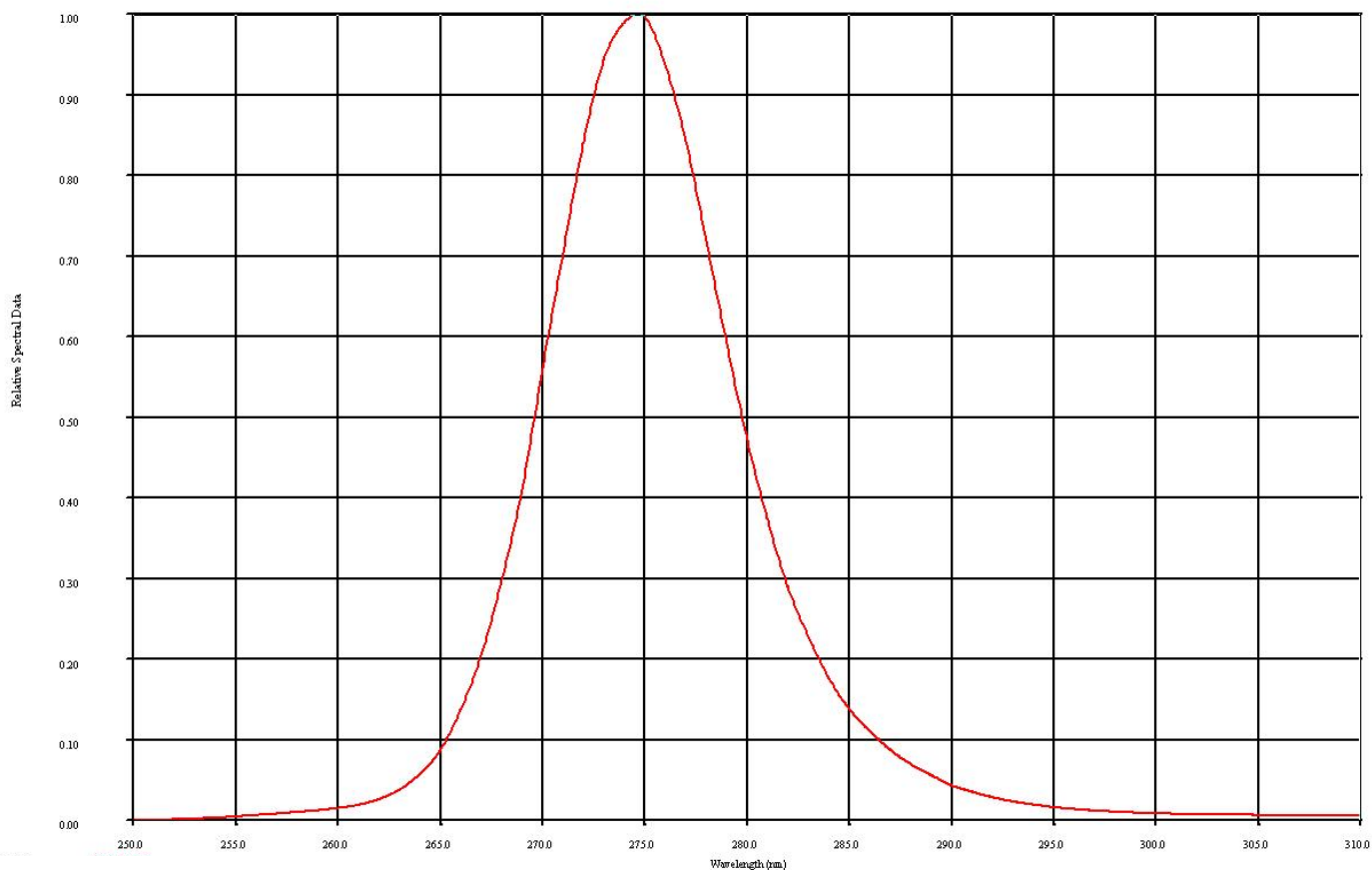

Radiation Distribution

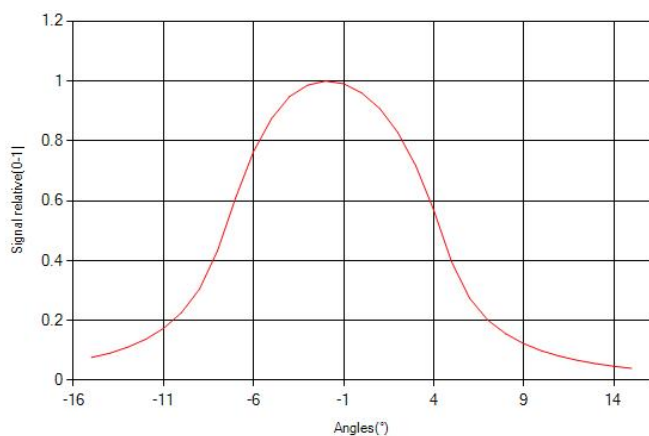

View Angle

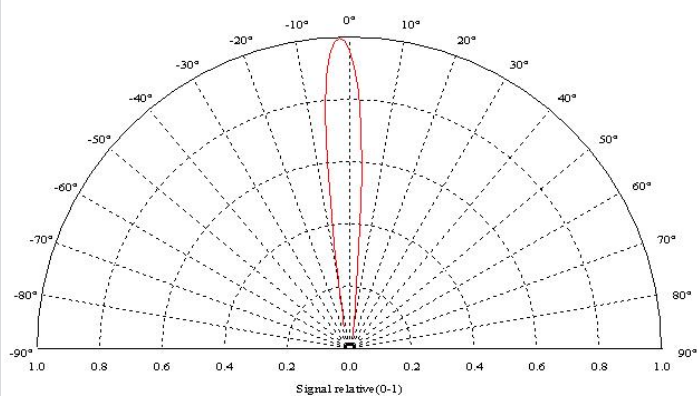

CAUTION

1. LEDs emit very strong UV radiation during operation.
2. Don't look directly into the LED light when in operation as UV radiation can harm your eyes.
3. To prevent even inadequate exposure, wear protective eyewear.
4. If LEDs are embedded in devices, please indicate warning labels against the UV LED used.
5. Avoid prolonged exposure to skin or other tissue during operation.
6. Keep out of reach of children.
7. Take appropriate precautions around pets and other living organisms to avoid UV exposure.
8. Specification and dimension are subject to change without notice.