



Peak Sensitivity Wavelength: 880nm

The **PT080N4** is a photo transistor in a TO-18 metal can domed package. It is well suited for high reliability and high sensitivity applications.

FEATURES

- > High Reliability in Demanding Environments
- > Narrow Angular Response
- > Metal Can Package
- > Compact

APPLICATIONS

- > Optical Switches
- > Edge Sensing
- > Fiber Optical Communications
- > Smoke Detectors



Absolute Maximum Ratings (Ta=25°C)



ITEMS	SYMBOL	RATINGS	UNIT
Collector-Emitter Voltage	Vceo	30	V
Emitter-Collector Voltage	Veco	5	V
Collector Current	Ic	50	mA
Collector Power Dissipation	Pc	150	mW
Operating Temperature Range	Topr	-30 ~ +100	°C
Storage Temperature Range	Tstg	-40 ~ +125	°C
Junction Temperature	Tj	125	°C
Lead Soldering Temperature*1	Tls	260	°C

*1: Time 5 Sec max, Position: Up to 3mm from the body.

Electrical & Optical Characteristics (Ta = 25°C)

ITEMS	SYMBOL	CONDITIONS	MIN	TYP	MAX	UNIT
Light Current	IL	Vce=20V, L=100Lux *1	--	3.0	--	mA
Dark Current	ID	Vce=20V	--	--	100	nA
C-E Saturation Voltage	VCE(sat)	Ic=0.2mA, L=1000Lux *1	--	0.2	--	V
Spectral Sensitivity	λ	--	--	400~1100	--	nm
Spectral Sensitivity	λ	*2	--	800~1100	--	nm
Peak Sensitivity Wavelength	λ_p	--	--	880	--	nm
Switching Time (Rise Time)	Tr	RL=100Ω, Vcc=5V, Ic=1mA	--	10.0	--	μS
Switching Time (Fall Time)	Tf	RL=100Ω, Vcc=5V, Ic=1mA	--	10.0	--	μS
Angular Response	Θ	--	--	±12	--	deg

*1: Color Temperature=2870°K Standard Tungsten Lamp, *2: With Daylight Filter Type (Sensing Only IR Rays) also Available.

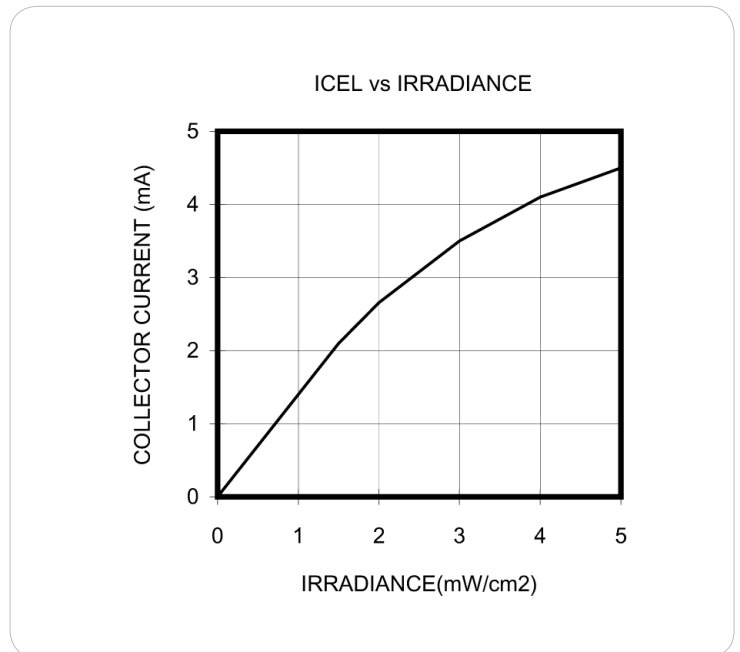
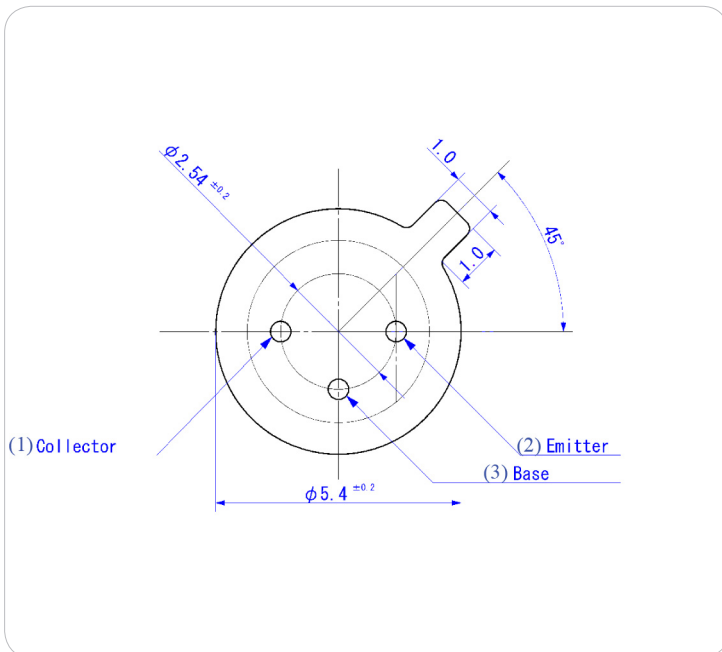
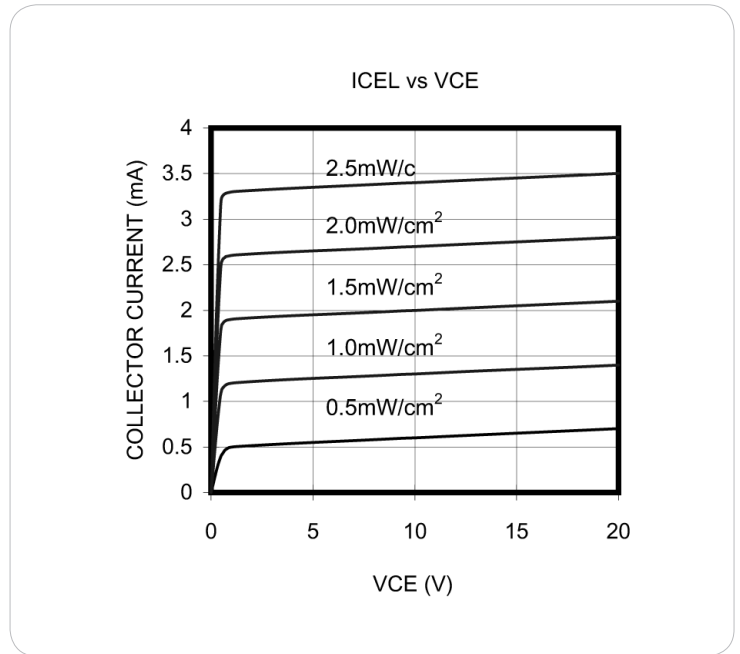
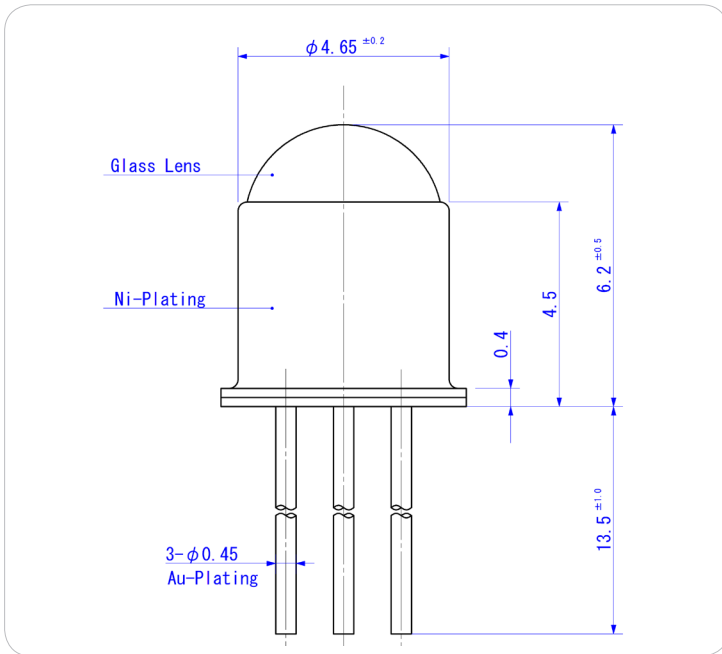

Unit: mm, Tolerance: ± 0.2



ANGULAR DISPLACEMENT

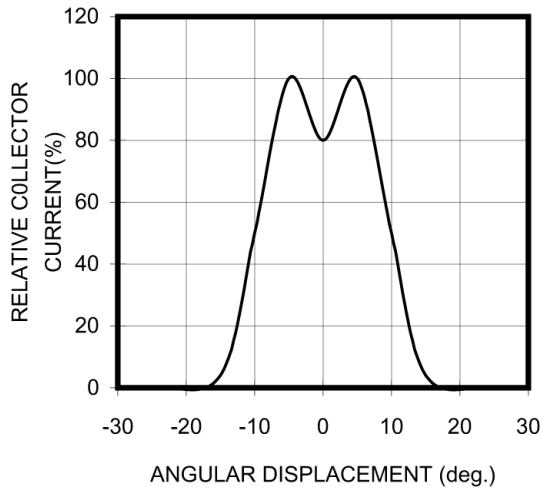

THERMAL DERATING COVE

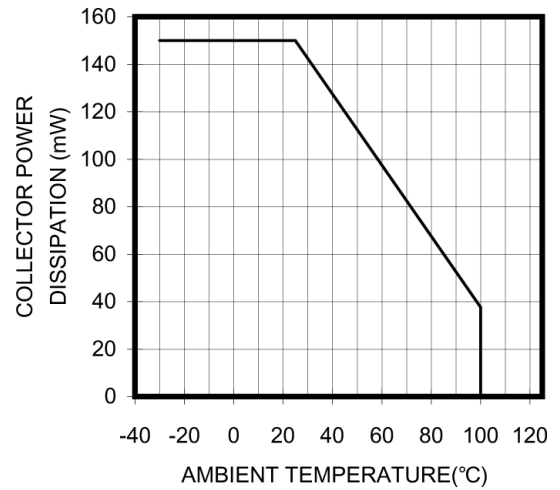

RELATIVE RESPONSE vs λ

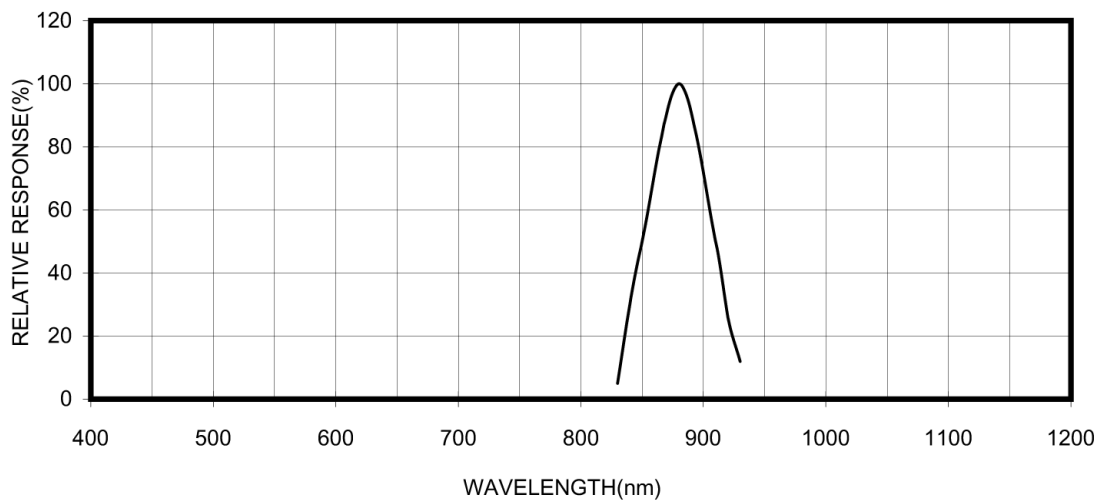

The information contained herein is subject to change without notice.

2011-07-19